



SIRCO

Load break switches for power distribution
from 125 to 5000 A



Load break
switches

new



SIRCO AC 3 x 250 A
direct handle



SIRCO 3 x 250 A
direct handle

The solution for

- > Main switchboard.
- > Distribution panel.
- > Emergency breaking.
- > Network coupling.
- > Local safety breaking.



Strong points

- > Reliability and performance.
- > Safety of property and personnel.
- > Simplicity.
- > Easy to install.

Enclosures

- > The SIRCO and SIRCO AC range can be easily fitted in our enclosures and cabinets designed for electrical distribution.

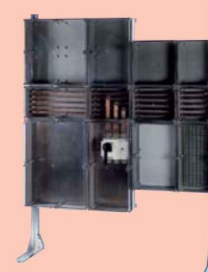

Function

SIRCO and SIRCO AC are manually operated multipolar load break switches. They make and break under load conditions and provide safety isolation. SIRCO are designed for 415 VAC and DC low voltage electrical circuits. SIRCO AC are designed for heavy duty applications up to 690 VAC - AC 23.

General characteristics

- Double positive break indication given through a position indication window, located directly on the product, and by the operating handle.
- Severe utilisation categories (AC-22 and AC-23).
- High resistance to damp heat (supplied "tropicalised").

Advantages

Reliability and performance

The SIRCO's double breaking per pole, achieved through its sliding bar contact system, is a proven design that offers very high durability and short-circuit withstand. The quick opening and rapid closure of the SIRCO's contacts, combined with specifically designed arcing chambers, provides the SIRCO AC with improved breaking performance.

Safety of property and personnel

The position indicator is located directly on the sliding bar contact mechanism, ensuring it can be seen in all circumstances.

The use of glass fibre reinforced polyester gives the SIRCO and SIRCO AC both high mechanical and thermal resistance.

Simplicity

The standardisation of the SIRCO and SIRCO AC range enables a cost reduction in stock management and storage thanks to their shared accessories.

Easy to install

Easy installation is facilitated thanks to:

- A good centre-to-centre distance (up to 120 mm).
- Connection up to 6x185 mm².
- Connection accessories which facilitate connection, both flat and edgewise connections.

What you need to know

- In front **direct** or **external** operation, SIRCO is available in 3 and 4 pole versions from 125 to 5000 A.
- It can be ordered in 6 or 8 pole versions from 125 to 1600 A.
- The switch is available in a polyester or sheet metal enclosure from 125 to 1250 A.

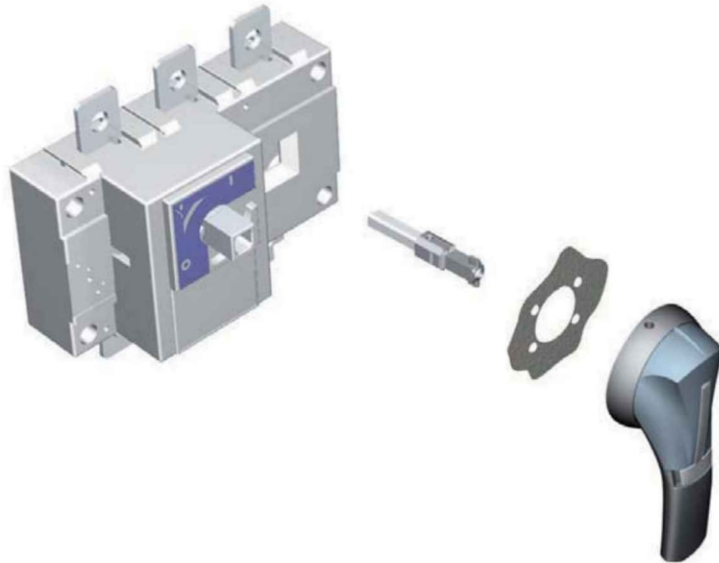

sirco_372_b_1_cat

For ratings 2000, 2500 and 3200A, a **copper bar connection kit** enables the connection between the two power terminals of one pole.

Flat connection
Top or bottom

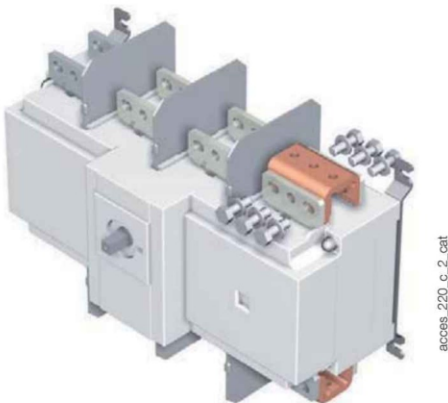

acces_220_c_2_cat

Edgewise connection
Top or bottom

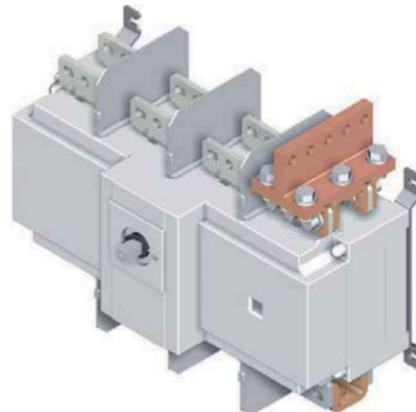

acces_223_b_2_cat

SIRCO - References

Front operation - 3 & 4 pole

Rating (A)	No. of poles	Switch body only ⁽¹⁾	Direct handle	External handle	Shaft for external handle	Auxiliary contact	Terminal shrouds	Terminal screens
125 A	3 P	2600 3014	B1 type Black 2699 5042 ⁽²⁾ Red 2699 5043				3 P 2694 3014 ⁽³⁾ 4 P 2694 4014 ⁽³⁾	3 P 2698 3012 ⁽³⁾ 4 P 2698 4012 ⁽³⁾
	4 P	2600 4014						
160 A	3 P	2600 3017						
	4 P	2600 4017						
200 A	3 P	2600 3021					3 P 2694 3021 ⁽³⁾ 4 P 2694 4021 ⁽³⁾	3 P 2698 3020 ⁽³⁾ 4 P 2698 4020 ⁽³⁾
	4 P	2600 4021						
250 A	3 P	2600 3026		S2 type Black IP55 1421 2111 ⁽²⁾ Black IP65 1423 2111 Red IP65 1424 2111	200 mm 1400 1020 320 mm 1400 1032 ⁽²⁾ 500 mm 1400 1050			
	4 P	2600 4026						
315 A	3 P	2600 3032	B2 type Black 2699 5052 ⁽²⁾ Red 2699 5053					
	4 P	2600 4032						
400 A	3 P	2600 3041					3 P 2694 3051 ⁽³⁾ 4 P 2694 4051 ⁽³⁾	3 P 2698 3050 ⁽³⁾ 4 P 2698 4050 ⁽³⁾
	4 P	2600 4041						
500 A	3 P	2600 3051						
	4 P	2600 4051						
630 A	3 P	2600 3064						
	4 P	2600 4064						
800 A	3 P	2600 3081				1 st contact NO/NC 2699 0031 2 nd contact NO/NC 2699 0032		3 P 2698 3080 ⁽³⁾ 4 P 2698 4080 ⁽³⁾
	4 P	2600 4081						
1000 A	3 P	2600 3099						
	4 P	2600 4099						
CD 1250 A	3 P	2600 3119		S4 type Black IP65 1443 3111 ⁽²⁾ Red IP65 1444 3111	200 mm 1401 1520 320 mm 1401 1532 ⁽²⁾ 400 mm 1401 1540			
	4 P	2600 4119						
1250 A	3 P	2600 3121						
	4 P	2600 4121						
1600 A	3 P	2600 3161	C2 type Black 2799 7012 ⁽²⁾ Red 2799 7013					3 P 2698 3120 ⁽³⁾ 4 P 2698 4120 ⁽³⁾
	4 P	2600 4161						
1800 A	3 P	2600 3181						
	4 P	2600 4181						
2000 A	3 P	2600 3200						
	4 P	2600 4200						
2500 A	3 P	2600 3250		V2 type Black IP65 2799 7136 ⁽²⁾ Red IP65 2799 7134	200 mm 2799 3015 320 mm 2799 3018 ⁽²⁾ 450 mm 2799 3019			3 P 2698 3200 ⁽³⁾ 4 P 2698 4200 ⁽³⁾
	4 P	2600 4250						
3200 A	3 P	2600 3320						
	4 P	2600 4320						
4000 A	3 P	2600 3401	V0 type Black 2799 7072 ⁽²⁾	V0 type Black IP65 2799 7155 ⁽²⁾				
	4 P	2600 4401						
5000 A	3 P	2600 3500				1 st /2 nd contact NO/NC included		
	4 P	2600 4500						

(1) Device available enclosed (see "Enclosed load break switches" page 600).

(2) Standard.

(3) Top or bottom.

SIRCO AC - References

Heavy duty applications - Front operation 3 & 4 pole

Rating (A)	No. of poles	Switch body	Direct handle	External handle	Shaft for external handle	Auxiliary contact	Terminal shrouds	Terminal screens
200 A	3 P	26AC 3020	J1 type Black 1112 1111 ⁽¹⁾ J1 type Red 1113 1111	S2 type Black IP55 1421 2111 ⁽¹⁾ Black IP65 1423 2111 Red IP65 1424 2111	200 mm 1400 1020 320 mm 1400 1032 ⁽¹⁾ 500 mm 1400 1050		3P 2694 3021 ⁽²⁾⁽³⁾ 4 P 2694 4021 ⁽²⁾⁽³⁾	3P 2698 3020 ⁽³⁾ 4 P 2698 4020 ⁽³⁾
	4 P	26AC 4020						
250 A	3 P	26AC 3025						
	4 P	26AC 4025						
315 A	3 P	26AC 3031						
	4 P	26AC 4031						
400 A	3 P	26AC 3040						
	4 P	26AC 4040						
500 A	3 P	26AC 3050						
	4 P	26AC 4050						
CD 630 A	3 P	26AC 3063						
	4 P	26AC 4063						
630 A	3 P	26AC 3064	J4 type Black 1142 1111 ⁽¹⁾ Red 1143 1111	S4 type Black IP65 1443 3111 ⁽¹⁾ Red IP65 1444 3111	200 mm 1401 1520 320 mm 1401 1532 ⁽¹⁾ 400 mm 1401 1540	1 st contact NO/NC 2699 0031 2 nd contact NO/NC 2699 0032	3P 2698 3051 ⁽²⁾⁽³⁾ 4 P 2694 4051 ⁽²⁾⁽³⁾	3P 2698 3050 ⁽³⁾ 4 P 2698 4050 ⁽³⁾
	4 P	26AC 4064						
800 A	3 P	26AC 3080						
	4 P	26AC 4080						
1000 A	3 P	26AC 3100						
	4 P	26AC 4100						
CD 1250 A	3 P	26AC 3120						
	4 P	26AC 4120						
1250 A	3 P	26AC 3121						
	4 P	26AC 4121						
1600 A	3 P	26AC 3160						
	4 P	26AC 4160						
2000 A	3 P	26AC 3200	S5 type Black 2799 7042 ⁽¹⁾ Red 2799 7043	S5 type Black IP65 1453 8111 ⁽¹⁾ Red IP65 1454 8111	200 mm 2799 3015 320 mm 2799 3018 ⁽¹⁾ 450 mm 2799 3019		3P 2698 3200 ⁽²⁾⁽³⁾ 4 P 2698 4200 ⁽²⁾⁽³⁾	
	4 P	26AC 4200						
4000 A	3 P	26AC 3400	V0 type Black 2799 7072 ⁽¹⁾	V0 type Black 2799 7155 ⁽¹⁾		1 st / 2 nd included	3/4P 1509 4200 ⁽⁴⁾	
	4 P	26AC 4400						

(1) Standard.

(2) Mandatory for voltage greater than 415 VAC.

(3) Top or bottom.

(4) Top and bottom.

SIRCO - References

Standard applications - Front operation - 6 & 8 pole

Rating (A)	No. of poles	Switch body	Direct handle	External handle	Shaft for external handle	Auxiliary contact	Terminal shrouds	Terminal screens
125 A	6 P	2601 6013	B3 type Black 4199 5012 ⁽¹⁾	S2 Type Black IP65 1421 2111 ⁽¹⁾ Red IP65 1424 2111	200 mm 1400 1020 320 mm 1400 1032 ⁽¹⁾		6 P 2694 3014 ⁽²⁾⁽³⁾ 8 P 2694 4014 ⁽²⁾⁽³⁾	6 P 1509 3012 ⁽⁴⁾ 8 P 1509 4012 ⁽⁴⁾
	8 P	2601 8013						
160 A	6 P	2601 6016						
	8 P	2601 8016						
250 A	6 P	2601 6025	C1 type Black 2799 7052 ⁽¹⁾ Red 2799 7053	S4 type Black IP65 1443 3111 ⁽¹⁾ Red IP65 1444 3111	200 mm 1401 1520 320 mm 1401 1532 ⁽¹⁾	1 st contact NO/NC 2699 0061 2 nd contact NO/NC 2699 0062	6 P 2694 3021 ⁽²⁾⁽³⁾ 8 P 2694 4021 ⁽²⁾⁽³⁾	6 P 1509 3025 ⁽⁴⁾ 8 P 1509 4025 ⁽⁴⁾
	8 P	2601 8025						
400 A	6 P	2601 6040						
	8 P	2601 8040						
630 A	6 P	2601 6063	C1 type Black 2799 7012 ⁽¹⁾ Red 2799 7013	V1 type Black IP65 2799 7145 ⁽¹⁾	320 mm 2799 3018 ⁽¹⁾		6 P 2694 3051 ⁽²⁾⁽³⁾ 8 P 2694 4051 ⁽²⁾⁽³⁾	6 P 1509 3063 ⁽⁴⁾ 8 P 1509 4063 ⁽⁴⁾
	8 P	2601 8063						
800 A	6 P	2601 6080						
	8 P	2601 8080						
1000 A	6 P	2601 6100						6 P 1509 3080 ⁽⁴⁾ 8 P 1509 4080 ⁽⁴⁾
	8 P	2601 8100						
1250 A	6 P	2601 6120						
	8 P	2601 8120						
1600 A	6 P	2601 6160						6 P 1509 3160 ⁽⁴⁾ 8 P 1509 4160 ⁽⁴⁾
	8 P	2601 8160						

(1) Standard.

(2) Upstream or downstream at the front or rear of the device.

(3) Select 2 sets for front or rear.

(4) Upstream or downstream at the front of the device.

Accessories

Direct operation handle

SIRCO direct operation handle				
Rating (A)	No. of poles	Handle	Handle colour	Reference
125 ... 160	3/4 P	B1 type	Black	2699 5042 ⁽¹⁾
125 ... 160	3/4 P	B1 type	Red	2699 5043
125 ... 160	6/8 P	B3 type	Black	4199 5012 ⁽¹⁾
200 ... 630	3/4 P	B2 type	Black	2699 5052 ⁽¹⁾
200 ... 630	3/4 P	B2 type	Red	2699 5053
250 ... 630	6/8 P	C1 type	Black	2799 7052 ⁽¹⁾
250 ... 630	6/8 P	C1 type	Red	2799 7053
800 ... 3200	3/4 P	C2 type	Black	2799 7012 ⁽¹⁾
800 ... 3200	3/4 P	C2 type	Red	2799 7013
800 ... 1600	6/8 P	C2 type	Black	2799 7012 ⁽¹⁾
800 ... 1600	6/8 P	C2 type	Red	2799 7013
4000 ... 5000	3/4 P	V0 type	Black	2799 7072 ⁽¹⁾

(1) Standard.



SIRCO AC direct operation handle				
Rating (A)	No. of poles	Handle	Handle colour	Reference
200 ... CD 630	3/4 P	J1 type	Black	1112 1111 ⁽¹⁾
200 ... CD 630	3/4 P	J1 type	Red	1113 1111
630 ... 1600	3/4 P	J4 type	Black	1142 1111 ⁽¹⁾
630 ... 1600	3/4 P	J4 type	Red	1143 1111
2000	3/4 P	S5 type	Black	2799 7042 ⁽¹⁾
2000	3/4 P	S5 type	Red	2799 7043
4000	3/4 P	V0 type	Black	2799 7072 ⁽¹⁾

(1) Standard.

Door interlocked external operation handle

SIRCO and SIRCO AC external front operation handle						
Rating (A) SIRCO	Rating (A) SIRCO AC	No. of poles	Handle	Handle colour	External IP ⁽¹⁾	Reference
125 ... 630	200 ... CD 630	3/4 P	S2 type	Black	IP55	1421 2111 ⁽²⁾⁽³⁾
				Black	IP65	1423 2111
				Red	IP65	1424 2111
125 ... 160		6/8 P	S2 type	Black	IP55	1421 2111 ⁽²⁾
				Black	IP65	1423 2111
250 ... 630		6/8 P	S4 type	Black	IP65	1443 3111
				Red	IP65	1444 3111
800 ... 1600	630 ... 1600	6/8 P	V1 type	Black	IP65	2799 7145 ⁽²⁾
800 ... 1800		3/4 P	S4 type	Black	IP65	1443 3111 ⁽²⁾⁽³⁾
2000 ... 3200	2000	3/4 P	S4 type	Black	IP65	1444 3111
				Black	IP65	2799 7136 ⁽²⁾
			S5 type	Red	IP65	2799 7134
				Black	IP65	1453 8111 ⁽³⁾
4000 ... 5000	4000	3/4 P	V0 type	Red	IP65	1454 8111
				Black	IP65	2799 7155 ⁽²⁾⁽³⁾

(1) IP: protection degree according to IEC 60529 standard.

(2) Standard.

Use

Door interlocked external operation handles include an escutcheon, are padlockable and must be utilised with an extension shaft.



Shaft for external handle

For 3/4 pole SIRCO and SIRCO AC				
Rating (A) SIRCO	Rating (A) SIRCO AC	Dimension X (mm)	Length (mm)	Reference
125 ... 160		125 ... 250	200	1400 1020
		125 ... 300	250	1400 1025
		125 ... 370	320	1400 1032
		125 ... 550	500	1400 1050
		125 ... 850	750	1400 1075
200 ... 250	200 ... 315	135 ... 265	200	1400 1020
		135 ... 315	250	1400 1025
		135 ... 385	320	1400 1032
		135 ... 565	500	1400 1050
		135 ... 880	750	1400 1075
315 ... 630	400 ... CD 630	165 ... 295	200	1400 1020
		165 ... 345	250	1400 1025
		165 ... 415	320	1400 1032
		165 ... 595	500	1400 1050
		165 ... 940	750	1400 1075
800 ... 1800	630 ... 1600	221 ... 343	200	1401 1520
		221 ... 463	320	1401 1532
		221 ... 543	400	1401 1540
2000 ... 3200	2000	415 ... 570	200	2799 3015
		415 ... 690	320	2799 3018
		415 ... 820	450	2799 3019
4000 ... 5000	4000	550 ... 680	200	2799 3015
		651 ... 921	320	2799 3018

Use

Standard lengths:

- 200 mm
- 250 mm
- 300 mm
- 400 mm
- 500 mm
- 750 mm

Other lengths: Please consult us.



access_368_a_1_X_cat

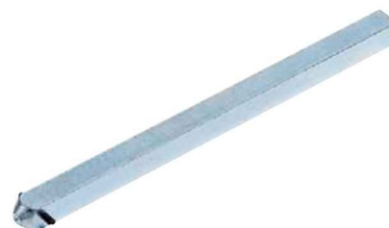

access_144_b_1_cat

For 6/8 pole SIRCO			
Rating (A)	Dimension X (mm)	Length (mm)	Reference
125 ... 160	270 ... 436	200	1400 1020
125 ... 160	270 ... 556	320	1400 1032
250 ... 630	221 ... 308	200	1400 1520
250 ... 630	221 ... 428	320	1400 1532
250 ... 630	221 ... 508	400	1400 1540

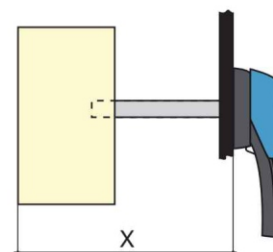

access_202_a_1_X_cat

Accessories (continued)

Alternative S-type handle cover colours

Use

For single lever handles S1, S2, S3 type and for double lever handle S4 type.
Other colours: Please consult us.

Handle colour	To be ordered in multiples of	Handle	Reference
Light grey	50	S2, S3 type	1401 0001
Dark grey	50	S2, S3 type	1401 0011
Light grey	50	S4 type	1401 0031
Dark grey	50	S4 type	1401 0041



S-type cover

access_198_a_2_cat

S-type handle adapter

Use

Enables S-type handles to be fitted in place of older style Socomec handles. Adapter can be utilised as a spacer to increase the distance between the panel door and the handle lever.
Adds 12 mm to the depth.

Handle colour	To be ordered in multiples of	External IP ⁽¹⁾	Reference
Black	1	IP65	1493 0000

(1) IP: protection degree according to IEC 60529 standard.



access_187_a_1_cat

Shaft guide for external operation

Use

For utilisation with S-type handles, to guide the shaft extension into the external handle. This accessory enables the handle to engage the extension shaft with a misalignment of up to 15 mm.
Required for shaft lengths over 320 mm.

Description	Reference
Shaft guide	1429 0000



access_260_a_2_cat

SIRCO

Load break switches for power distribution
from 125 to 5000 A



Auxiliary contact

Use

- Pre-break and signalling of positions 0 and I:
- 1 to 2 NO/NC auxiliary contacts.
- 1 to 4 NO+NC auxiliary contacts.
- 1 to 2 low level NO/NC auxiliary contacts.

Characteristics

NO/NC A/C: IP2 with front operation.

Connection to the control circuit

6.35 mm fast-on terminal.

Electrical characteristics

30 000 operations.

NO/NC contact for 3/4 pole SIRCO and SIRCO AC

Rating (A)	Position A/C	Reference
125 ... 3200	1 st	2699 0031
125 ... 3200	2 nd	2699 0032
4000 ... 5000	1 st /2 nd	included

NO/NC contact for 6/8 pole SIRCO

Rating (A)	Position A/C	Reference
125 ... 1600	1 st	2699 0061
125 ... 1600	2 nd	2699 0062

NO+NC contact for 3/4 pole SIRCO and SIRCO AC

Rating (A)	Position A/C	Reference
125 ... 3200	1 st	2699 0141
125 ... 3200	2 nd /3 rd /4 th	2699 0142

NO/NC low level contact for 3/4 pole SIRCO and SIRCO AC

Rating (A)	Position A/C	Reference
125 ... 3200	1 st	2699 0301
125 ... 3200	2 nd	2699 0302

Characteristics

Rating (A)	Contact type	Current nominal (A)	Operating current I _o (A)									
			230 VAC		400 VAC		24 VDC		48 VDC			
			AC-12	AC-13/15	AC-12	AC-13/15	DC-12	DC-13	DC-12	DC-13		
125 ... 3200	NO/NC	16	16	4	12	3	2.5	2.5	1	2.5	1.2	0.2
125 ... 3200	NO + NC	16	16	4	16	3	16	5	1	2.5	1.2	0.2

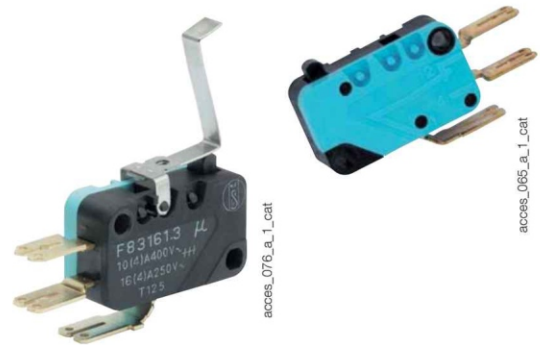

Inter-phase barrier

Use

Safety isolation between the terminals, essential for use at 690 VAC or in a polluted or dusty atmosphere.



For 3/4 poles

Rating (A) SIRCO	Rating (A) SIRCO AC	No. of poles	Reference
125 ... 160		3 P	2998 0033
125 ... 160		4 P	2998 0034
200 ... 250	200 ... 315	3 P	2998 0023
200 ... 250	200 ... 315	4 P	2998 0024
315 ... 630	315 ... CD 360	3 P	2998 0013
315 ... 630	315 ... CD 360	4 P	2998 0014
800 ... 5000	630 ... 4000	3 P	included
800 ... 5000	630 ... 4000	4 P	included

Terminal shrouds

Use

Top or bottom protection against direct contact with terminals or connection parts.

Advantage

Perforations allow remote thermographic inspection without the need to remove the shrouds. The terminal shrouds also provide phase separation for SIRCO and SIRCO AC 125 to 630 A.



access_077_a_1_Cat

For 3/4 poles				
Rating (A) SIRCO	Rating (A) SIRCO AC	No. of poles	Position	Reference
125 ... 160		3 P	top or bottom	2694 3014 ⁽¹⁾
125 ... 160		4 P	top or bottom	2694 4014 ⁽²⁾
200 ... 250	200 ... 315	3 P	top or bottom	2694 3021 ⁽¹⁾
200 ... 250	200 ... 315	4 P	top or bottom	2694 4021 ⁽²⁾
315 ... 630	400 ... CD 630	3 P	top or bottom	2694 3051 ⁽¹⁾
315 ... 630	400 ... CD 630	4 P	top or bottom	2694 4051 ⁽²⁾

(1) Reference includes 3 parts for top or bottom protection.
(2) Reference includes 4 parts for top or bottom protection.

For 6/8 pole SIRCO			
Rating (A)	No. of poles	Position	Reference
125 ... 160	6 P	top or bottom	2694 3014 ⁽¹⁾⁽³⁾
125 ... 160	8 P	top or bottom	2694 4014 ⁽²⁾⁽³⁾
250	6 P	top or bottom	2694 3021 ⁽¹⁾⁽³⁾
250	8 P	top or bottom	2694 4021 ⁽²⁾⁽³⁾
400 ... 630	6 P	top or bottom	2694 3051 ⁽¹⁾⁽³⁾
400 ... 630	8 P	top or bottom	2694 4051 ⁽²⁾⁽³⁾

(1) Reference includes 3 parts for top or bottom protection on the front or rear of the device.
(2) Reference includes 4 parts for top or bottom protection on the front or rear of the device.
(3) Select 2 sets for front or rear.

Distribution block

Use

Easy connection of several cables, downstream of the SIRCO.

For 3/4 pole SIRCO				
Rating (A)	No. of poles	No of feeders per section (mm ²)	I _{cc} (kA rms) ⁽¹⁾	Reference
160	3 P	1x95 + 8x25	10	5411 3016
160	4 P	1x95 + 8x25	10	5411 6016
250	3 P	1x150 + 8x50	15	5411 3025
250	4 P	1x150 + 8x50	15	5411 4025
400	3 P	1x240 + 8x95	21	5411 3040
400	4 P	1x240 + 8x95	21	5411 4040
630	3 P	1x300 + 8x150	21	5411 3063
630	4 P	1x300 + 8x150	21	5411 4063

Dimensions

Rating (A)	No. of poles	A	W	E	H	K	D	R	T	Y
160	3 P	154	286	73	46.5	261.5	36	20	4	54
160	4 P	190	286	73	46.5	261.5	36	20	4	54
250	3 P	210	307	83	57.5	279	50	25	4	56
250	4 P	260	307	83	57.5	279	50	25	4	56
400	3 P	281	375	116	82.5	340	65	32	5	82
400	4 P	346	375	116	82.5	340	65	32	5	82
630	3 P	271	438	117	90.5	410.5	65	40	6	83
630	4 P	346	438	117	90.5	410.5	65	40	6	83



repair_020_c_2_Cat

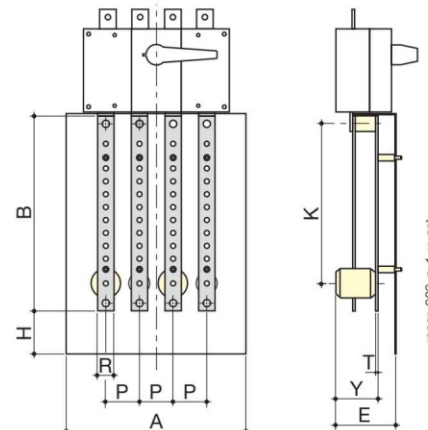

repair_003_c_1_X_Cat

Terminal screens

Use

Top and bottom protection against direct contact with terminals or connection parts.

For 3/4 poles				
Rating (A) SIRCO	Rating (A) SIRCO AC	No. of poles	Position	Reference
125 ... 160		3 P	top or bottom	2698 3012
125 ... 160		4 P	top or bottom	2698 4012
200 ... 250	200 ... 315	3 P	top or bottom	2698 3020
200 ... 250	200 ... 315	4 P	top or bottom	2698 4020
315 ... 630	400 ... CD 630	3 P	top or bottom	2698 3050
315 ... 630	400 ... CD 630	4 P	top or bottom	2698 4050
800 ... CD 1250	630 ... CD 1250	3 P	top or bottom	2698 3080
800 ... CD 1250	630 ... CD 1250	4 P	top or bottom	2698 4080
1250 ... 1800	1250 ... 1600	3 P	top or bottom	2698 3120
1250 ... 1800	1250 ... 1600	4 P	top or bottom	2698 4120
2000 ... 3200	2000	3 P	top or bottom	2698 3200
2000 ... 3200	2000	4 P	top or bottom	2698 4200
4000 ... 5000	4000	3/4 P	top or bottom	1509 4200



eccecs_0179_a_1_cat

For 6/8 pole SIRCO			
Rating (A)	No. of poles	Position	Reference
125 ... 160	6 P	top or bottom	1509 3012
125 ... 160	8 P	top or bottom	1509 4012
250	6 P	top or bottom	1509 3025
250	8 P	top or bottom	1509 4025
400 ... 630	6 P	top and bottom	1509 3063
400 ... 630	8 P	top and bottom	1509 4063
800 ... 1250	6 P	top and bottom	1509 3080
800 ... 1250	8 P	top and bottom	1509 4080
1600	6 P	top and bottom	1509 3160
1600	8 P	top and bottom	1509 4160

Cage terminals

Use

They enable a direct terminal-free connection to rigid copper and aluminium conductors with integration under the IP2X protective cover.

Material: tin-plated aluminium.

Dimensions

Rating (A)	A	A1	C	E	R	T	ØX	X1	Z
125 ... 160	47.5	22.5	25	12	20	3.5	8.5	M12	10
200 ... 250	62	31.5	31.5	16.5	25	2.5	10.5	M16	14
315 ... 400	71.5	32	38	9	32	5	10.5	M20	15
500 ... 630	76.5	37	38	9	40	5	12.5	M20	15

References

Rating (A)	Tightening capacity (mm²)	No. of poles	Tightening torque (Nm)	Width of flexible bar (mm)	Reference
125 ... 160	16 ... 95	3 P	14	13	5400 3016
125 ... 160	16 ... 95	4 P	14	13	5400 4016
200 ... 250	16 ... 185	3 P	25	18	5400 3025
200 ... 250	16 ... 185	4 P	25	18	5400 4025
315 ... 400	50 ... 240	3 P	45	20	5400 3040
315 ... 400	50 ... 240	4 P	45	20	5400 4040
500 ... 630	70 ... 300	3 P	45	24	5400 3063
500 ... 630	70 ... 300	4 P	45	24	5400 4063

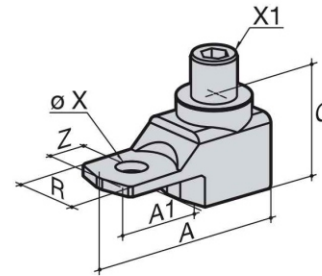

bom_0179_a_1_x_cat

Accessories (continued)

Copper bar connection kits

Use

To allow connection between the two power terminals of the same pole for 2000 to 3200 A ratings (Fig. 1 and Fig 2).

For 3200 A rating, the connection pieces (part A) are delivered bridged from factory.1

Bolt sets must be ordered separately.

Further details for these specific accessories are available in the user guide downloadable from www.socomec.com.

Fig. 1

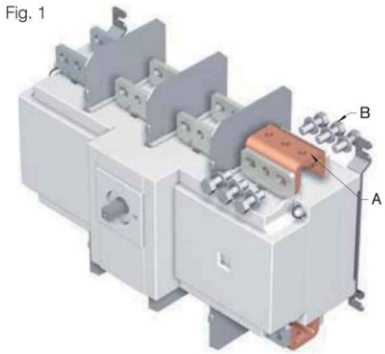

access_220_c_1_x_cat

Top or bottom flat connection - Fig. 1			
Rating (A)	Piece	Quantity to order per pole ⁽¹⁾	Reference
2000 ... 2500	Connection - part A	1	2619 1200
2000 ... 2500	Bolt set - part B	1	2699 1200
3200	Connection - part A		included
3200	Bolt set - part B	1	2699 1200

⁽¹⁾ Example for a 3 pole device equipped upstream only: Order 3 times the indicated quantities.

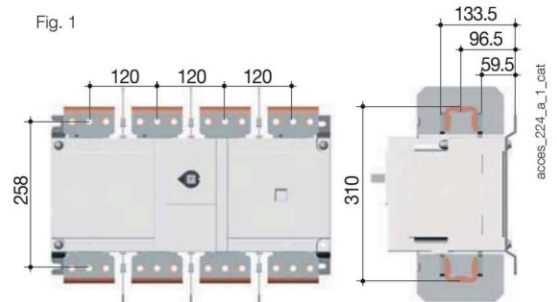

access_224_a_1_x_cat

Top or bottom edgewise connection - Fig. 2			
Rating (A)	Piece	Quantity to order per pole ⁽¹⁾	Reference
2000 ... 2500	Connection - part A	1	2619 1200
2000 ... 2500	T piece - part C	1	2629 1200 ⁽²⁾
2000 ... 2500	Bracket - part D	1	2639 1200 ⁽²⁾
3200	Connection - part A		included
3200	T piece - part C	1	2629 1200
3200	Bracket - part D	1	2639 1200

⁽¹⁾ Example for a 3 pole device equipped upstream only: Order 3 times the indicated quantities.

⁽²⁾ Bolt set is provided with the accessories.

Fig.2

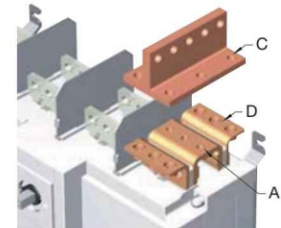

access_222_b_1_x_cat

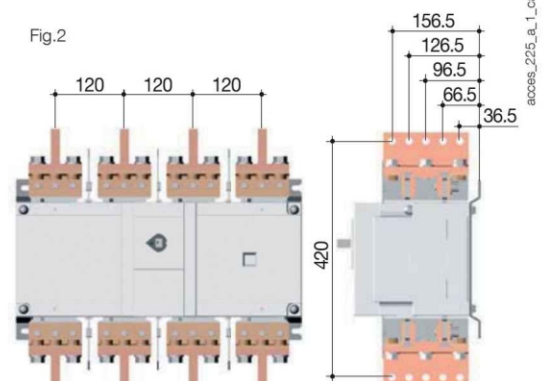

access_225_a_1_x_cat

Key handle interlocking system

Use

Locking in position 0 of the front operation handle:

- using a padlock (not supplied) - function is available as standard on the handle. From 125 to 1800 A, the padlock on the external front operation handle also locks

- the door,
- using lock (not supplied): see diagrams opposite,
- using undervoltage coil: the SIRCO can only be closed if the coil is live.

For 6/8 pole: Please consult us

For SIRCO

Locking using RONIS EL11AP lock (not supplied)					
Rating (A)	No. of poles	Operation	Figure	Reference	
125 ... 630	3/4 P	front direct	1	2699	6008 ⁽¹⁾
125 ... 1800	3/4 P	external front	3	1499	7701
800 ... 3200	3/4 P	front direct	2	2699	6027
1250 ... 5000	3/4 P	external front	4	2799	7002

(1) Front handle operation included.

For SIRCO AC

Locking using RONIS EL11AP lock (not supplied)					
Rating (A)	No. of poles	Operation	Figure	Reference	
200 ... CD 630	3/4 P	front direct	1	2699	6011 ⁽¹⁾
630 ... 1600	3/4 P	front direct	2	2699	6028

For SIRCO

Locking using 230 VAC undervoltage coil (other voltages: please consult us)					
Rating (A)	No. of poles	Operation	Figure	Reference	
125 ... 630	3/4 P	external front		2699	9063 ⁽¹⁾
800 ... 3200	3/4 P	front direct		2699	9315 ⁽¹⁾

(1) The locking system is directly mounted on the device.

Locking using CASTELL lock (not supplied)						
Rating (A)	No. of poles	Handle	Lock type	Operation	Figure	Reference
125 ... 160	6/8 P	S2 type	K	External front	2	4109 8507
125 ... 1 800	3/4 P	S2, S4 type	FS	External front	3	1499 7703
125 ... 1 800	3/4 P	S2, S4 type	K	External front	3	1499 7702
250 ... 630	6/8 P	S4 type	K	External front	2	2999 8707
800 ... 1 600	6/8 P	S5 type	K	External front	2	2799 7003
1 250 ... 4 000	3/4 P	S5, S0 type	K	External front	2	2799 7003

Fig. 1

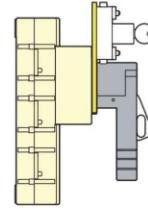

Fig.2

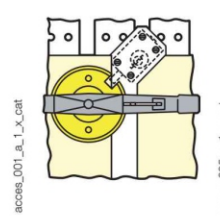

Fig. 3

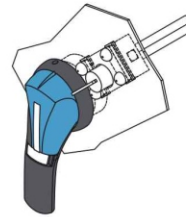
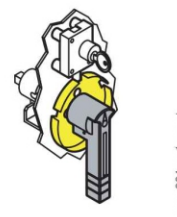

Fig.4



Other specific accessories



- Mechanical coupling device for making switches with "n" poles of the same or different ratings.
- Mechanical interlocking device.

SIRCO characteristics according to IEC 60947-3

125 to 800 A

Thermal current I_{th} at 40°C	125 A	160 A	200 A	250 A	315 A	400 A	500 A	630 A	800 A
Rated insulation voltage U_i (V)	800	800	800	800	1000	1000	1000	1000	1000
Rated impulse withstand voltage U_{imp} (kV)	8	8	8	8	12	12	12	12	12

Rated operational currents I_e (A)

Rated voltage	Utilisation category	A/B ⁽¹⁾	A/B ⁽¹⁾	A/B ⁽¹⁾	A/B ⁽¹⁾	A/B ⁽¹⁾	A/B ⁽¹⁾	A/B ⁽¹⁾	A/B ⁽¹⁾	A/B ⁽¹⁾
415 VAC	AC-20 A / AC-20 B	125/125	160/160	200/200	250/250	315/315	400/400	500/500	630/630	800/800
415 VAC	AC-21 A / AC-21 B	125/125	160/160	200/200	250/250	315/315	400/400	500/500	630/630	800/800
415 VAC	AC-22 A / AC-22 B	125/125	160/160	200/200	250/250	315/315	400/400	500/500	630/630	800/800
415 VAC	AC-23 A / AC-23 B	125/125	160/160	200/200	250/250	315/315	400/400	500/500	630/630	800/800
220 VDC	DC-20 A / DC-20 B	125/125	160/160	200/200	250/250	315/315	400/400	500/500	630/630	800/800
220 VDC	DC-21 A / DC-21 B	125/125	160/160	160/200	250/250	315/315	400/400	500/500	630/630	800/800
220 VDC	DC-22 A / DC-22 B	125/125	160/160	160/200	250/250	315/315	400/400	500/500	630/630	800/800
220 VDC	DC-23 A / DC-23 B	125/125	125/125	160/160	200/200	315/315	400/400	500/500	630/630	800/800
440 VDC	DC-20 A / DC-20 B	125/125	160/160	200/200	250/250	315/315	400/400	500/500	630/630	800/800
440 VDC	DC-21 A / DC-21 B	125 ⁽³⁾ /125 ⁽³⁾	160 ⁽³⁾ /160 ⁽³⁾	160 ⁽³⁾ /200 ⁽³⁾	200 ⁽³⁾ /200 ⁽³⁾	315 ⁽³⁾ /315 ⁽³⁾	400 ⁽³⁾ /400 ⁽³⁾	400 ⁽³⁾ /400 ⁽³⁾	500 ⁽³⁾ /500 ⁽³⁾	800 ⁽⁴⁾ /800 ⁽⁴⁾
440 VDC	DC-22 A / DC-22 B	125 ⁽³⁾ /125 ⁽³⁾	125 ⁽³⁾ /125 ⁽³⁾	160 ⁽³⁾ /160 ⁽³⁾	200 ⁽³⁾ /200 ⁽³⁾	315 ⁽³⁾ /315 ⁽³⁾	400 ⁽³⁾ /400 ⁽³⁾	400 ⁽³⁾ /400 ⁽³⁾	500 ⁽³⁾ /500 ⁽³⁾	800 ⁽⁴⁾ /800 ⁽⁴⁾
440 VDC	DC-23 A / DC-23 B	125 ⁽⁴⁾ /125 ⁽⁴⁾	125 ⁽⁴⁾ /125 ⁽⁴⁾	160 ⁽⁴⁾ /160 ⁽⁴⁾	200 ⁽⁴⁾ /200 ⁽⁴⁾	315 ⁽⁴⁾ /315 ⁽⁴⁾	400 ⁽⁴⁾ /400 ⁽⁴⁾	400 ⁽⁴⁾ /400 ⁽⁴⁾	500/500	800 ⁽⁴⁾ /800 ⁽⁴⁾
500 VDC	DC-20 A / DC-20 B	125/125	160/160	200/200	250/250	315/315	400/400	500/500	630/630	800/800
500 VDC	DC-21 A / DC-21 B	125 ⁽³⁾ /125 ⁽³⁾	125 ⁽³⁾ /125 ⁽³⁾	160 ⁽³⁾ /200 ⁽³⁾	200 ⁽³⁾ /200 ⁽³⁾	315 ⁽³⁾ /315 ⁽³⁾	400 ⁽³⁾ /400 ⁽³⁾	400 ⁽³⁾ /400 ⁽³⁾	500 ⁽³⁾ /500 ⁽³⁾	800 ⁽⁴⁾ /800 ⁽⁴⁾
500 VDC	DC-22 A / DC-22 B	125 ⁽⁴⁾ /125 ⁽⁴⁾	125 ⁽⁴⁾ /125 ⁽⁴⁾	160 ⁽⁴⁾ /160 ⁽⁴⁾	200 ⁽⁴⁾ /200 ⁽⁴⁾	315 ⁽⁴⁾ /315 ⁽⁴⁾	315 ⁽⁴⁾ /400 ⁽⁴⁾	315 ⁽⁴⁾ /400 ⁽⁴⁾	500 ⁽⁴⁾ /500 ⁽⁴⁾	800 ⁽⁴⁾ /800 ⁽⁴⁾
500 VDC	DC-23 A / DC-23 B	125 ⁽⁴⁾ /125 ⁽⁴⁾	125 ⁽⁴⁾ /125 ⁽⁴⁾	160 ⁽⁴⁾ /160 ⁽⁴⁾	200 ⁽⁴⁾ /200 ⁽⁴⁾	315 ⁽⁴⁾ /315 ⁽⁴⁾	315 ⁽⁴⁾ /400 ⁽⁴⁾	315 ⁽⁴⁾ /400 ⁽⁴⁾	500 ⁽⁴⁾ /500 ⁽⁴⁾	800 ⁽⁴⁾ /800 ⁽⁴⁾

Operational power in AC-23 A (kW) ⁽¹⁾⁽⁵⁾

At 415 VAC without pre-break in AC ⁽¹⁾	63/63	80/80	100/100	132/132	160/160	220/220	280/280	280/280	450/450
---	-------	-------	---------	---------	---------	---------	---------	---------	---------

Reactive power (kvar)

At 400 VAC (kvar) ⁽⁵⁾	55	75	90	115	145	185	230	290	365
----------------------------------	----	----	----	-----	-----	-----	-----	-----	-----

Fuse protected short-circuit withstand (kA rms prospective)⁽⁶⁾

Prospective short-circuit current (kA rms)	100	100	80	50	100	100	100	70	50
Associated fuse rating (A)	125	160	200	250	315	400	500	630	800

Circuit breaker protected short-circuit withstand with any circuit breaker that ensures tripping in less than 0.3s at 690 VAC

Rated short-time withstand current 0.3s. I_{cw} (kA rms)	15	15	17	17	25	25	25	25	50
--	----	----	----	----	----	----	----	----	----

Short-circuit capacity (without protection)

Rated short-time withstand current 1s. I_{cw} (kA rms)	7	7	9	9	13	13	13	13	35
Rated short-circuit making capacity without fuses I_{cm} (kA peak)	11.9	11.9	15.3	15.3	26	26	26	26	73.5

Connection

Maximum Cu cable cross-section (mm ²)	35	50	70	95	150	185	240	2 x 150	2 x 185
Minimum Cu busbar cross-section (mm ²)								2 x 30 x 5	2 x 40 x 5
Maximum Cu cable cross-section (mm ²)	50	95	95	150	240	240	240	2 x 300	2 x 300
Maximum Cu busbar width (mm)	25	25	32	32	40	40	40	50	63
Tightening torque min/max (Nm)	9/-	9/-	20/-	20/-	20/-	20/-	20/-	20/-	40/45

Mechanical characteristics

Durability (number of operating cycles)	10000	10000	10000	10000	10000	10000	10000	10000	3000
Operating effort (Nm)	6.5	6.5	10	10	10	14.5	14.5	14.5	37
Weight of a 3 pole device (kg)	1	1.5	2	2	3.5	3.5	3.5	3.5	8
Weight of a 4 pole device (kg)	1.5	1.5	2	2	4	4	4.5	4.5	10

(1) Category with index A = frequent operation - Category with index B = infrequent operation.

(2) With terminal shrouds or phase barrier.

(3) 3-pole device with 2 pole in series for the "+" and 1 pole for the "-".

(4) 4-pole device with 2 poles in series per polarity.

(5) The power value is given for information only, the current values vary from one manufacturer to another.

(6) For a rated operational voltage $U_n = 415$ VAC.

SIRCO characteristics according to IEC 60947-3

1000 to 5000 A

Thermal current I_{th} at 40°C	1000 A	CD 1250 A	1250 A	1600 A	1800 A	2000 A	2500 A	3200 A	4000 A	5000 A
Rated insulation voltage U_i (V)	1000	1000	1000	1000	1000	1000	1000	1000	1000	1000
Rated impulse withstand voltage U_{imp} (kV)	12	12	12	12	12	12	12	12	12	12

Rated operational currents I_e (A)

Rated voltage	Utilisation category	A/B ⁽¹⁾	A/B ⁽¹⁾	A/B ⁽¹⁾	A/B ⁽¹⁾	A/B ⁽¹⁾	A/B ⁽¹⁾	A/B ⁽¹⁾	A/B ⁽¹⁾	A/B ⁽¹⁾	A/B ⁽¹⁾
415 VAC	AC-20 A / AC-20 B	1000/1000	1250/1250	1250/1250	1600/1600	1800/1800	2000/2000	2500/2500	3200/3200	4000/4000	5000/5000
415 VAC	AC-21 A / AC-21 B	1000/1000	1250/1250	1250/1250	1600/1600	1800/1800	2000/2000	2500/2500	3200/3200	4000/4000	5000/5000
415 VAC	AC-22 A / AC-22 B	1000/1000	1250/1250	1250/1250	1600/1600	1800/1800	2000/2000	2500/2500	2500/3200	2500/3200	2500/3200
415 VAC	AC-23 A / AC-23 B	1000/1000	1250/1250	1250/1250	1250/1250	1250/1250	1600/1600	1600/1600	1600/1600	1800/2000	1800/2000
220 VDC	DC-20 A / DC-20 B	1000/1000	1250/1250	1250/1250	1600/1600	1800/1800	2000/2000	2500/2500	3200/3200	4000/4000	5000/5000
220 VDC	DC-21 A / DC-21 B	1000/1000	1250/1250	1250/1250	1250/1600	1250/1600	2000/2000	2000/2500	2000/2500	2500/3200	2500/3200
220 VDC	DC-22 A / DC-22 B	1000/1000	1250/1250	1250/1250	1250/1250	1250/1250	1250/1600	1250/1600	1250/1600	1800/2000	1800/2000
220 VDC	DC-23 A / DC-23 B	1000/1000	1250/1250	1250/1250	1250/1250	1250/1250	1250/1250	1250/1250	1250/1250	1250/1600	1250/1600
440 VDC	DC-20 A / DC-20 B	1000/1000	1250/1250	1250/1250	1600/1600	1800/1800	2000/2000	2500/2500	3200/3200	4000/4000	5000/5000
440 VDC	DC-21 A / DC-21 B	1000 ⁽⁴⁾ /1000 ⁽⁴⁾	1250 ⁽⁴⁾ /1250 ⁽⁴⁾	1250 ⁽⁴⁾ /1250 ⁽⁴⁾	1250 ⁽⁴⁾ /1600 ⁽⁴⁾	1250 ⁽⁴⁾ /1600 ⁽⁴⁾	2000 ⁽⁴⁾ /2000 ⁽⁴⁾	2000 ⁽⁴⁾ /2500 ⁽⁴⁾	2500 ⁽⁴⁾ /3200 ⁽⁴⁾	3200 ⁽⁴⁾ /4000 ⁽⁴⁾	3200 ⁽⁴⁾ /5000 ⁽⁴⁾
440 VDC	DC-22 A / DC-22 B	1000 ⁽⁴⁾ /1000 ⁽⁴⁾	1250 ⁽⁴⁾ /1250 ⁽⁴⁾	1250 ⁽⁴⁾ /1250 ⁽⁴⁾	1250 ⁽⁴⁾ /1250 ⁽⁴⁾	1250 ⁽⁴⁾ /1250 ⁽⁴⁾	1250 ⁽⁴⁾ /1250 ⁽⁴⁾	1250 ⁽⁴⁾ /1250 ⁽⁴⁾	1250 ⁽⁴⁾ /1250 ⁽⁴⁾	1600 ⁽⁴⁾ /1800 ⁽⁴⁾	1600 ⁽⁴⁾ /1800 ⁽⁴⁾
440 VDC	DC-23 A / DC-23 B	1000 ⁽⁴⁾ /1000 ⁽⁴⁾	1250 ⁽⁴⁾ /1250 ⁽⁴⁾	1250 ⁽⁴⁾ /1250 ⁽⁴⁾	1250 ⁽⁴⁾ /1250 ⁽⁴⁾	1250 ⁽⁴⁾ /1250 ⁽⁴⁾	1250 ⁽⁴⁾ /1250 ⁽⁴⁾	1250 ⁽⁴⁾ /1250 ⁽⁴⁾	1250 ⁽⁴⁾ /1250 ⁽⁴⁾	1250 ⁽⁴⁾ /1250 ⁽⁴⁾	1250 ⁽⁴⁾ /1250 ⁽⁴⁾
500 VDC	DC-20 A / DC-20 B	1000/1000	1250/1250	1250/1250	1600/1600	1800/1800	2000/2000	2500/2500	3250/3250	4000/4000	5000/5000
500 VDC	DC-21 A / DC-21 B	1000 ⁽⁴⁾ /1000 ⁽⁴⁾	1250 ⁽⁴⁾ /1250 ⁽⁴⁾	1250 ⁽⁴⁾ /1250 ⁽⁴⁾	1250 ⁽⁴⁾ /1600 ⁽⁴⁾	1250 ⁽⁴⁾ /1600 ⁽⁴⁾	1250 ⁽⁴⁾ /1250 ⁽⁴⁾	1250 ⁽⁴⁾ /1250 ⁽⁴⁾	1250 ⁽⁴⁾ /1250 ⁽⁴⁾	1600 ⁽⁴⁾ /1800 ⁽⁴⁾	1600 ⁽⁴⁾ /1800 ⁽⁴⁾
500 VDC	DC-22 A / DC-22 B	1000 ⁽⁴⁾ /1000 ⁽⁴⁾	1250 ⁽⁴⁾ /1250 ⁽⁴⁾	1250 ⁽⁴⁾ /1250 ⁽⁴⁾	1250 ⁽⁴⁾ /1250 ⁽⁴⁾	1250 ⁽⁴⁾ /1250 ⁽⁴⁾	1250 ⁽⁴⁾ /1250 ⁽⁴⁾	1250 ⁽⁴⁾ /1250 ⁽⁴⁾	1250 ⁽⁴⁾ /1250 ⁽⁴⁾	1250 ⁽⁴⁾ /1600 ⁽⁴⁾	1250 ⁽⁴⁾ /1600 ⁽⁴⁾
500 VDC	DC-23 A / DC-23 B	1000 ⁽⁴⁾ /1000 ⁽⁴⁾	1250 ⁽⁴⁾ /1250 ⁽⁴⁾	1250 ⁽⁴⁾ /1250 ⁽⁴⁾	1250 ⁽⁴⁾ /1250 ⁽⁴⁾	1250 ⁽⁴⁾ /1250 ⁽⁴⁾	1000 ⁽⁴⁾ /1000 ⁽⁴⁾	1000 ⁽⁴⁾ /1000 ⁽⁴⁾	1000 ⁽⁴⁾ /1000 ⁽⁴⁾	1000 ⁽⁴⁾ /1000 ⁽⁴⁾	1000 ⁽⁴⁾ /1000 ⁽⁴⁾

Operational power in AC-23 A (kW) ⁽¹⁾⁽⁵⁾

At 415 VAC without pre-break in AC ⁽¹⁾	560/560	710/710	710/710	710/710	710/710	710/710	710/710	710/710	710/710	710/710	710/710
---	---------	---------	---------	---------	---------	---------	---------	---------	---------	---------	---------

Reactive power (kvar)

At 400 VAC (kvar) ⁽⁵⁾	460										
----------------------------------	-----	--	--	--	--	--	--	--	--	--	--

Fuse protected short-circuit withstand (kA rms prospective)⁽⁶⁾

Prospective short-circuit current (kA rms)	100	100	100	100	100	100	100				
Associated fuse rating (A)	1000	1250	1250	2 x 800	2 x 800	2 x 1000	2 x 1250				

Circuit breaker protected short-circuit withstand with any circuit breaker that ensures tripping in less than 0.3s at 690 VAC

Rated short-time withstand current 0.3s. I_{cw} (kA rms)	65	65	100	100	100	100	100	100	100		
--	----	----	-----	-----	-----	-----	-----	-----	-----	--	--

Short-circuit capacity (without protection)

Rated short-time withstand current 1s. I_{cw} (kA rms)	35	35	50	50	50	50	50	50	50	75	75
Rated short-circuit making capacity without fuses I_{cm} (kA peak)	73.5	73.5	75	75	75	80	80	80	80	165	165

Connection

Maximum Cu cable cross-section (mm ²)	2 x 240										
Minimum Cu busbar cross-section (mm ²)	2 x 50 x 5	2 x 60 x 5	2 x 60 x 5	2 x 80 x 5	3 x 100 x 5	3 x 100 x 5	4 x 100 x 5	4 x 100 x 5	4 x 100 x 5	1 x 100 x 5	1 x 100 x 5
Maximum Cu cable cross-section (mm ²)	4 x 185	4 x 185	4 x 185	6 x 185	6 x 185						
Maximum Cu busbar width (mm)	63	63	100	100	100	100	100	100	100		
Tightening torque min/max (Nm)	40/45	40/45	40/45	40/45	40/45	40/45	40/45	40/-	40/-	40/-	40/-

Mechanical characteristics

Durability (number of operating cycles)	3000	3000	4000	4000	4000	3000	3000	3000	3000	2000	2000
Operating effort (Nm)	37	37	56	56	56	75	75	75	75	105	105
Weight of a 3 pole device (kg)	8	8	12	12	12	22	22	22	22	45	45
Weight of a 4 pole device (kg)	10	10	15	15	15	25	25	25	25	50	50

(1) Category with index A = frequent operation - Category with index B = infrequent operation.

(2) With terminal shrouds or phase barrier.

(3) 3-pole device with 2 pole in series for the "+" and 1 pole for the "-".

(4) 4-pole device with 2 poles in series per polarity.

(5) The power value is given for information only, the current values vary from one manufacturer to another.

(6) For a rated operational voltage $U_e = 415$ VAC.

SIRCO AC characteristics according to IEC 60947-3

200 to 630 A

Thermal current I_{th} at 40°C	200 A	250 A	315 A	400 A	500 A	CD 630 A	630 A
Rated insulation voltage U_i (V)	1000	1000	1000	1000	1000	1000	1000
Rated impulse withstand voltage U_{imp} (kV)	12	12	12	12	12	12	12

Rated operational currents I_e (A)

Rated voltage	Utilisation category	A/B ⁽¹⁾	A/B ⁽¹⁾	A/B ⁽¹⁾	A/B ⁽¹⁾	A/B ⁽¹⁾	A/B ⁽¹⁾	A/B ⁽¹⁾
500 VAC	AC-20 A / AC-20 B	200/200	250/250	315/315	400/400	500/500	630/630	630/630
500 VAC	AC-21 A / AC-21 B	200/200	250/250	315/315	400/400	500/500	630/630	630/630
500 VAC	AC-22 A / AC-22 B	200/200	250/250	315/315	400/400	500/500	630/630	630/630
500 VAC	AC-23 A / AC-23 B	200/200	250/250	315/315	400/400	500/500	630/630	630/630
690 VAC	AC-20 A / AC-20 B	200/200	250/250	315/315	400/400	500/500	630/630	630/630
690 VAC	AC-21 A / AC-21 B	200/200	250/250	315/315	400 ⁽²⁾ /400 ⁽²⁾	500 ⁽²⁾ /500 ⁽²⁾	630 ⁽²⁾ /630 ⁽²⁾	630 ⁽²⁾ /630 ⁽²⁾
690 VAC	AC-22 A / AC-22 B	200/200	250/250	315/315	400 ⁽²⁾ /400 ⁽²⁾	500 ⁽²⁾ /500 ⁽²⁾	500 ⁽²⁾ /630 ⁽²⁾	630 ⁽²⁾ /630 ⁽²⁾
690 VAC	AC-23 A / AC-23 B	200/200	250/250	315/315	400 ⁽²⁾ /400 ⁽²⁾	500 ⁽²⁾ /500 ⁽²⁾	500 ⁽²⁾ /500 ⁽²⁾	630 ⁽²⁾ /630 ⁽²⁾

Operational power in AC-23 A (kW) ⁽⁵⁾

At 690 VAC without pre-break AC	160	220	250	400	500	500	630
---------------------------------	-----	-----	-----	-----	-----	-----	-----

Reactive power (kvar)

At 690 VAC (kvar)	160	190	250	325	400	400	450
-------------------	-----	-----	-----	-----	-----	-----	-----

Fuse protected short-circuit withstand (kA rms prospective) at 690 VAC ⁽⁶⁾

Prospective short-circuit current (kA rms)	50	50	50	50	50	50	50
Associated fuse rating (A)	200	250	315	400	500	630	630

Circuit breaker protected short-circuit withstand with any circuit breaker that ensures tripping in less than 0.3s at 690 VAC

Rated short-time withstand current 0.3s. I_{cw} (kA rms)	15	15	15	15	15	15	28
--	----	----	----	----	----	----	----

Short-circuit capacity (without protection)

Rated short-time withstand current 1s. I_{cw} (kA rms)	8	8	8	11	11	11	20
Rated short-circuit making capacity without fuses I_{cm} (kA peak)	22	22	22	22	22	22	40

Connection

Maximum Cu cable cross-section (mm ²)	70	70	70	185	240	2 x 150	2 x 185
Minimum Cu busbar cross-section (mm ²)						2 x 30 x 5	2 x 40 x 5
Maximum Cu cable cross-section (mm ²)	95	95	95	240	240	2 x 300	2 x 300
Maximum Cu busbar width (mm)	32	32	32	40	40	63	63
Tightening torque min/max (Nm)	20/-	20/-	20/-	20/-	20/-	20/-	40/45

Mechanical characteristics

Durability (number of operating cycles)	10000	10000	10000	5000	5000	5000	4000
Operating effort (Nm)	10	10	10	14.5	14.5	14.5	48
Weight of a 3 pole device (kg)	2	2	2	3.5	3.5	3.5	8
Weight of a 4 pole device (kg)	2	2	2	4	4	4	10

(1) Category with index A = frequent operation - Category with index B = infrequent operation.

(2) With terminal shrouds or phase barrier.

(3) 3-pole device with 2 poles in series for the "+" and 1 pole for the "-".

(4) 4-pole device with 2 poles in series per polarity.

(5) The power value is given for information only, the current values vary from one manufacturer to another.

(6) For a rated operational voltage $U_e = 690$ VAC.

SIRCO AC characteristics according to IEC 60947-3

800 to 4000 A

Thermal current I_{th} at 40°C	800 A	1000A	CD 1250 A	1250 A	1600 A	2000 A	4000 A
Rated insulation voltage U_i (V)	1000	1000	1000	1000	1000	1000	1000
Rated impulse withstand voltage U_{imp} (kV)	12	12	12	12	12	12	12
Rated operational currents I_e (A)							
Rated voltage	Utilisation category	A/B ⁽¹⁾	A/B ⁽¹⁾	A/B ⁽¹⁾	A/B ⁽¹⁾	A/B ⁽¹⁾	A/B ⁽¹⁾
500 VAC	AC-20 A / AC-20 B	800/800	1000/1000	1250/1250	1250/1250	1600/1600	4000/4000
500 VAC	AC-21 A / AC-21 B	800/800	1000/1000	1250/1250	1250/1250	1600/1600	-/3200
500 VAC	AC-22 A / AC-22 B	800/800	1000/1000	1250/1250	1250/1250	1600/1600	-
500 VAC	AC-23 A / AC-23 B	800/800	1000/1000	1250/1250	1250/1250	1600/1600	-
690 VAC	AC-20 A / AC-20 B	800/800	1000/1000	1250/1250	1250/1250	1600/1600	4000/4000
690 VAC	AC-21 A / AC-21 B	800/800	1000/1000	1250/1250	1250/1250	1600/1600	-/3200
690 VAC	AC-22 A / AC-22 B	800/800	1000/1000	1250/1250	1250/1250	1600/1600	-/-
690 VAC	AC-23 A / AC-23 B	800/800	1000/1000	1250/1250	1250/1250	1600/1600	-/-
Operational power in AC-23 A (kW) ⁽⁵⁾							
At 690 VAC without pre-break AC		900	900	-	-	-	-
Reactive power (kvar)							
At 690 VAC (kvar)		550	750	950	950	-	-
Fuse protected short-circuit withstand (kA rms prospective) at 690 VAC⁽⁶⁾							
Prospective short-circuit current (kA rms)		50	50	50	50	50	-
Associated fuse rating (A)		800	800	2 x 500	1250	2 x 800	-
Circuit breaker protected short-circuit withstand with any circuit breaker that ensures tripping in less than 0.3s at 690 VAC							
Rated short-time withstand current 0.3s. I_{cw} (kA rms)		28	55	55	53	53	53
Short-circuit capacity (without protection) at 690 VDC							
Rated short-time withstand current 1s. I_{cw} (kA rms)		20	30	30	35	35	35
Rated short-circuit making capacity without fuses I_{cm} (prospective kA peak)		40	80	80	75	75	75
Connection							
Maximum Cu cable cross-section (mm ²)		2 x 185	2 x 240				
Minimum Cu busbar cross-section (mm ²)		2 x 40 x 5	2 x 50 x 5	2 x 60 x 5	2 x 60 x 5	2 x 80 x 5	3 x 100 x 5
Maximum Cu cable cross-section (mm ²)		2 x 300	4 x 185	4 x 185	4 x 185	6 x 185	
Maximum Cu busbar width (mm)		63	63	63	100	100	100
Tightening torque min/max (Nm)		40/45	40/45	40/45	40	40	40
Mechanical characteristics							
Durability (number of operating cycles)		4000	4000	3000	4000	4000	2000
Operating effort (Nm)		48	48	48	55	55	100
Weight of a 3 pole device (kg)		8	8	8	12	12	45
Weight of a 4 pole device (kg)		10	10	10	15	15	50

(1) Category with index A = frequent operation - Category with index B = infrequent operation.

(2) With terminal shrouds or phase barrier.

(3) 3-pole device with 2 poles in series for the "+" and 1 pole for the "-".

(4) 4-pole device with 2 poles in series per polarity.

(5) The power value is given for information only, the current values vary from one manufacturer to another.

(6) For a rated operational voltage $U_e = 690$ VAC.

Dimensions - Front operation

SIRCO 125 to 630 A and SIRCO AC 200 to CD 630 A

Direct front operation

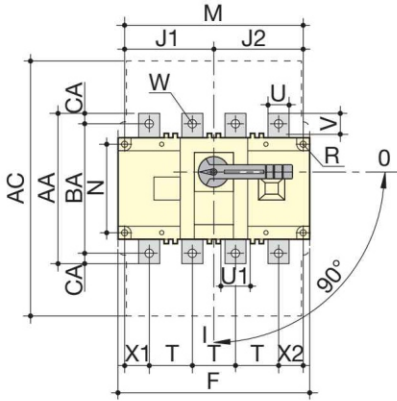

External front operation

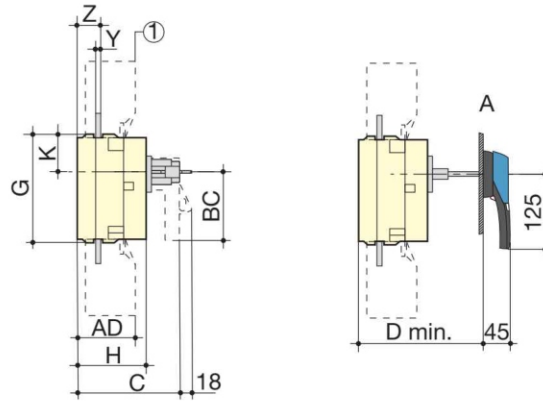

1. Terminal shrouds

A. S2 type handle

Rating (A) SIRCO	Rating (A) SIRCO AC	Overall dimensions		Terminal shrouds		Switch body										Switch mounting				Connection											
		C	D min	AC	AD	F 3p.	F 4p.	G	H	J1 3p.	J1 4p.	J2	K	BC	M 3p.	M 4p.	N	R	T	U	U1	V	W	X1 3p.	X1 4p.	X2	Y	Z	AA	BA	CA
125...160		115	125	235	50	140	170	93	65	45	75	75	31.5	80	120	150	65	5.5	36	20	20.5	25	9	28	22	20	3.5	20.5	135	115	10
200...250	200...250			280	60	180	230	108	75	55	105	105	34	115	160	210	80	5.5	50	20	25.5	21.5	11	33	33	27	3.5	22.5	160	130	15
315...400	400...500	160	165	401	89	230	290	170	110	75	135	135	55	115	210	270	140	7	65	32	29	11	42.5	37.5	37.5	5	36	235	205	15	
500	-			32	45.5	13	45	41.5																							
630	CD 630			45	41.5	13																									

SIRCO 800 to 1800 A and SIRCO AC 630 to 1600 A

Direct front operation

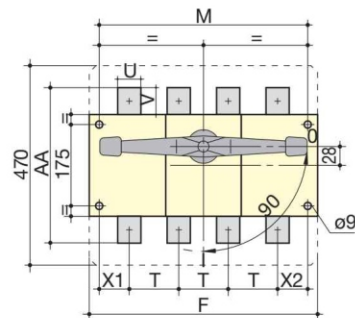

External front operation

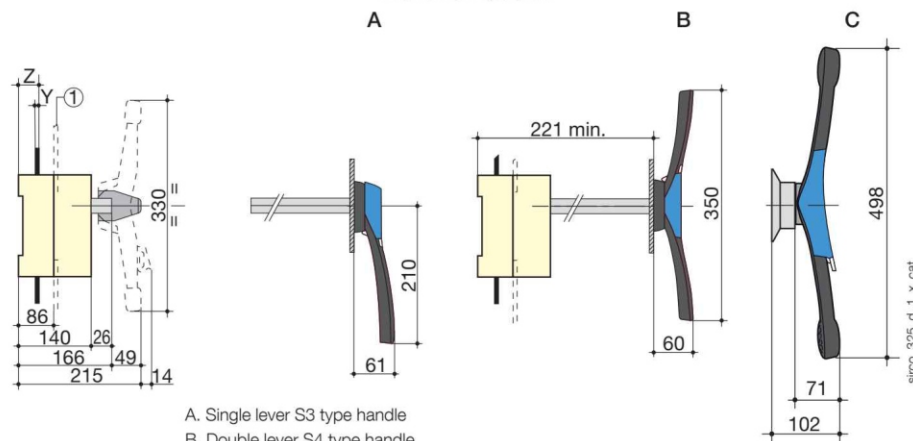

1. Terminal screens

A. Single lever S3 type handle

B. Double lever S4 type handle

C. Double lever S5 type handle

Rating (A) SIRCO	Rating (A) SIRCO AC	Switch body		Switch mounting		Connection									
		F 3p.	F 4p.	M 3p.	M 4p.	T	U	V	Y	X1	X2	Z	AA		
800 ... 1000	630 ... 1000	280	360	255	335	80	50	60.5	7	47.5	47.5	46.5	321		
CD 1250	CD 1250						60	65						330	
1250 ... 1800	1250 ... 1600	372	492	492	467	120	90	44	8	53.5	53.5	47.5	288		

SIRCO

Load break switches for power distribution
from 125 to 5000 A



SIRCO 2000 to 3200 A and SIRCO AC 2000 A

Direct front operation

External front operation

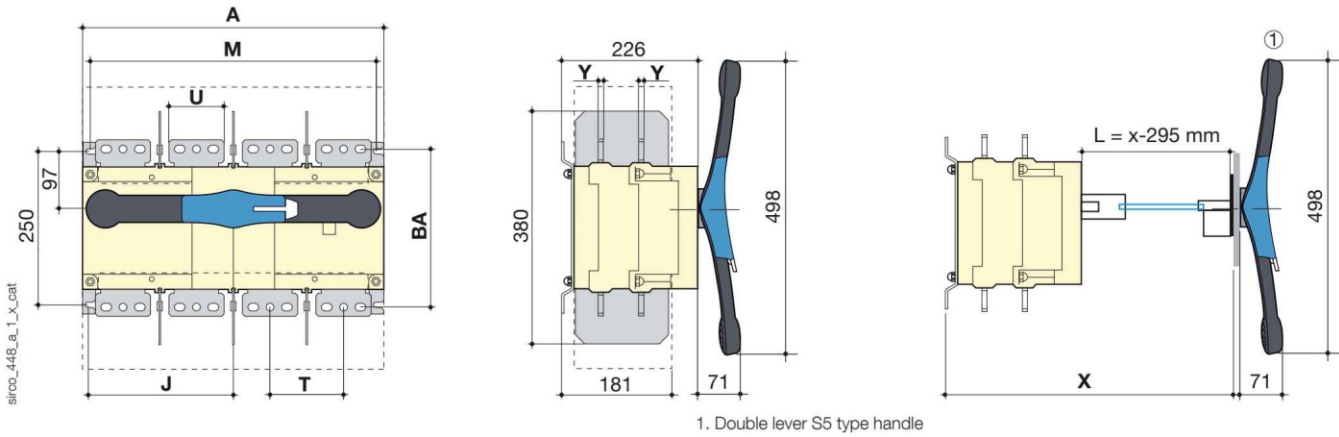

Rating (A) SIRCO	SIRCO AC rating (A)	Overall dimensions		Switch body		Switch mounting		Connection			
		A 3p.	A 4p.	J 3p.	J 4p.	M 3p.	M 4p.	T	U	Y	BA
2000 ... 3200	2000	372	492	173.5	233.5	347	367	120	90	8	258

SIRCO 4000 to 5000 A and SIRCO AC 4000 A

Direct front operation

External front operation

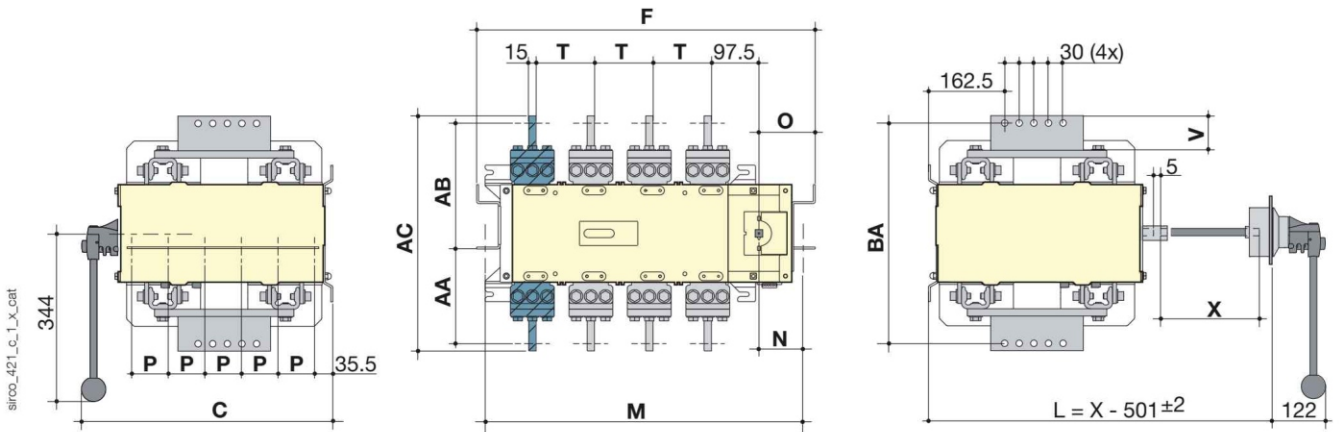

Rating (A) SIRCO	Rating (A) SIRCO AC	Overall dimensions C	Switch body		Switch mounting					Connection					
			F 3p.	F 4p.	M 3p.	M 4p.	N	O	D	T	V	AA	AB	AC	BA
4000 ... 5000	4000	514	695	695	660	660	98	115.5	75	120	86	160	292	482	452

Dimensions for external handles

SIRCO 125 to 630 A and SIRCO AC 200 to CD 630 A

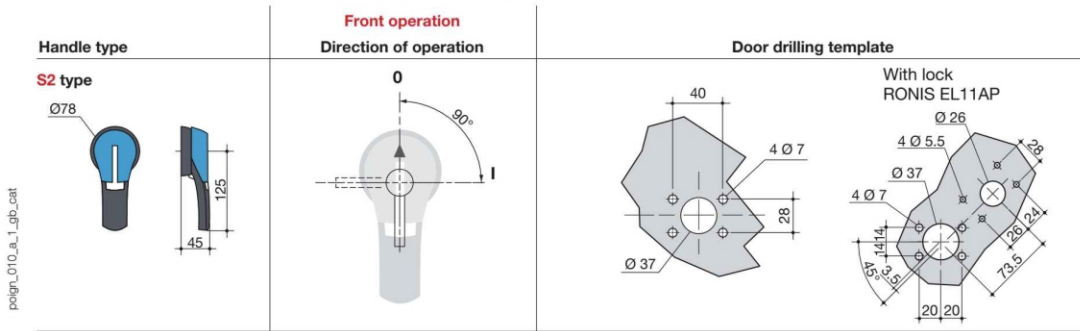

SIRCO 125 to 630 A

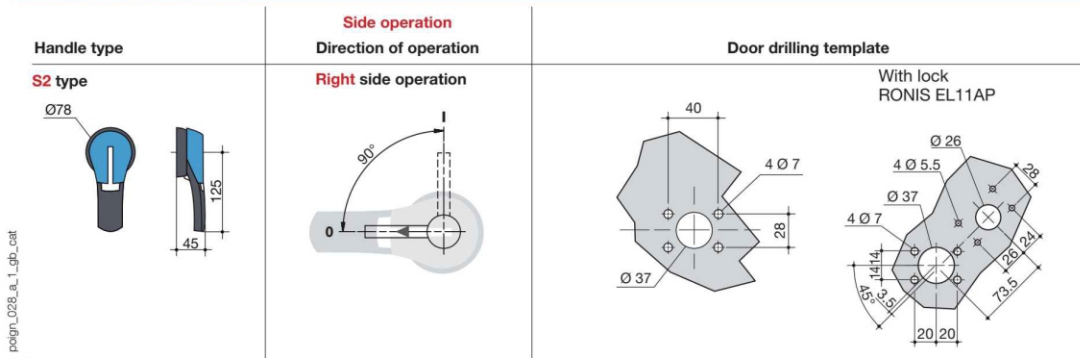

SIRCO 800 to 1800 A and SIRCO AC 630 to 1600 A

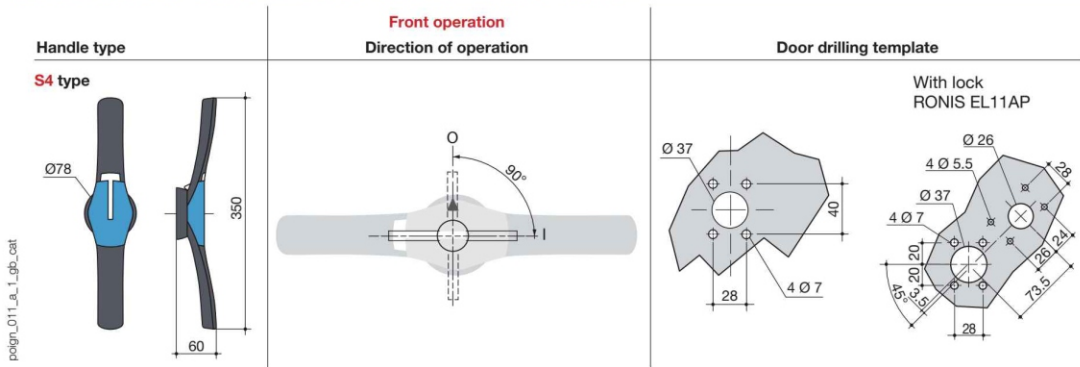

SIRCO 800 to 1800 A

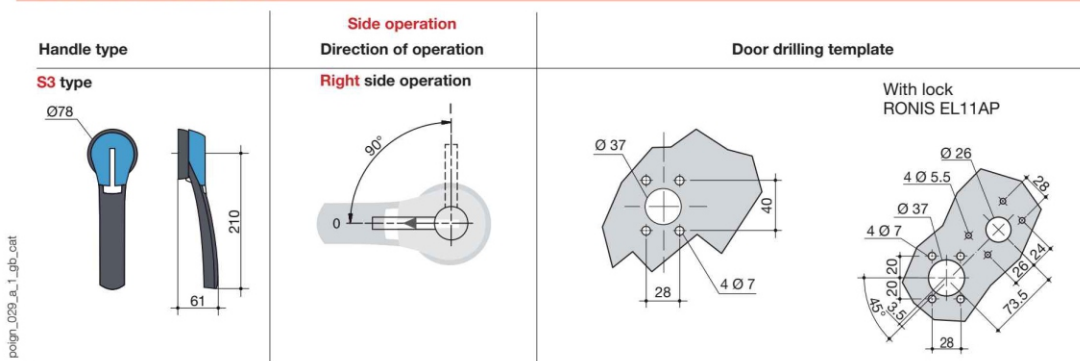

Dimensions for external handles (continued)

SIRCO 2000 to 3200 A

Handle type	Front operation Direction of operation	Door drilling template
V2 Type 		

SIRCO AC 2000 A

Handle type	Front operation Direction of operation	Door drilling
S5 type with V Escutcheon 		

SIRCO 4000 to 5000 A and SIRCO AC 4000 A

Handle type	Front operation Direction of operation	Door drilling
V0 type 		

Connection terminal

SIRCO 125 to 630 A and SIRCO AC 200 to CD 630 A

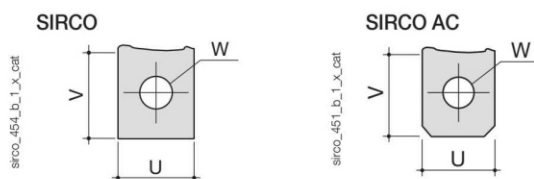

Rating (A)		U	V	W
SIRCO	SIRCO AC			
125 ... 160		20	25	9
200 ... 250	200 ... 250	25	21.5	11
	315	35		
315 ... 400	400 ... 500	32	29	13
500				
630	CD 630	45	41.5	

Connection terminal (continued)

SIRCO 800 to 1000 A and SIRCO AC 630 to 1000 A

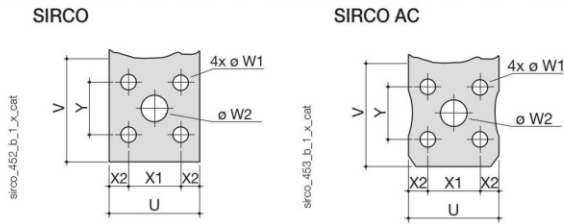

Rating (A)		U	V	W1	W1	X1	X2	Y
SIRCO	SIRCO AC	50	60.5	28.5	16	28.5	11	33
800 ... 1000	630 ... 1000							

SIRCO and SIRCO AC CD 1250 A

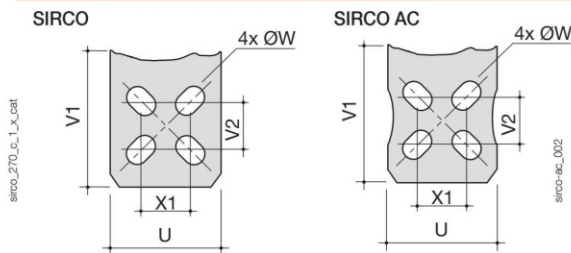

Rating (A)		U	V1	V2	W	X1	Y
SIRCO	SIRCO AC	60	65	28.5	16	28.5	11
CD 1250 A	CD 1250 A						

SIRCO 1250 to 3200 A and SIRCO AC 1250 to 1600 A

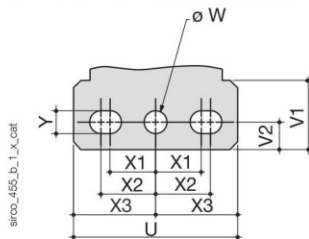

Rating (A)		U	V1	V2	W	X1	X2	X3	Y
SIRCO	SIRCO AC	90	35.8	15	12.5	25	30	45	12.5
1250 ... 3200	1250 ... 1600								

SIRCO 4000 to 5000 A and SIRCO AC 4000 A

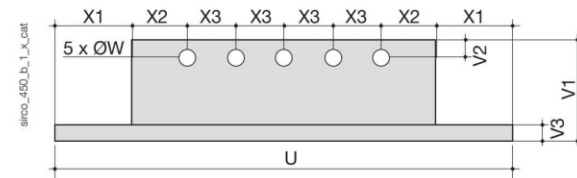

Rating (A)		U	W	X1	X2	X3	V1	V2	V3
SIRCO	SIRCO AC	286	13	48	35	30	86	15	15
4000 ... 5000	4000								